

**ELKO EP, s.r.o.**  
 Palackého 493  
 769 01 Holešov, Všetuly  
 Czech Republic  
 Tel.: +420 573 514 211  
 e-mail: elko@elkoep.com  
 www.elkoep.com

Made in Czech Republic

02-17/2017 Rev.: 0



## HRH-1

### Level switch



#### Characteristics

- used to control the level in wells, reservoirs, tanks, pools, tankers, containers, etc.
- within the framework of a single device, the following configurations can be selected (see functions graph):
  - two separate level switches
  - two probes in one tank
  - filling tank from well
- single-state monitors one level (full or empty tank), double-state monitors two levels (switches on upon one level and switches off upon the second)
- DIP switch on front panel is used to choose function (see functions graph):
  - pumping in
  - pumping out
  - over-pumping
- option of setting time delay for reacting to the output upon a change in level, any type of delay by DIP switch
- sensitivity adjustable by potentiometer (probe resistance based on fluid)
- the measuring frequency 500 Hz prevents fluid polarization and oxidation increase of measured probes
- galvanically separated supply AC 110 V, AC 230 V or AC/DC 24 V
- output contact 2x switches 16 A / 250 V AC1
- 3-MODULE design, mounting onto DIN rail

#### Symbol

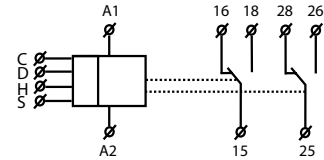

#### Connection

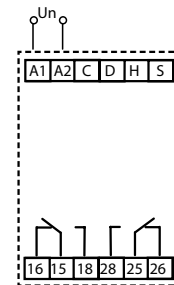

#### Description

- 
- Terminal for connection of conductor common for both probes
  - Supply voltage terminals
  - Supply voltage indication
  - H relay indication (OUT2)
  - D relay indication (OUT1)
  - Output contact of D relay - OUT1
  - Terminals for connecting probe
  - Terminals for connecting shield
  - Single / double relay function
  - Relay D function inversion
  - Relay D delay type selection
  - Relay H delay type selection
  - Delay setting relay H
  - Delay setting relay D
  - Sensitivity setting of probe according to resistance of measured fluid
  - Output contact of H relay - OUT2

Type of load	$\cos \varphi \geq 0.95$	AC2	AC3	AC5a uncompensated	AC5a compensated	AC5b	AC6a	AC7b	AC12
Mat. contacts AgNi, contact 16A	250V / 16A	250V / 5A	250V / 3A	230V / 3A (690VA)	x	800W	x	250V / 3A	250V / 10A
Type of load	AC13	AC14	AC15	DC1	DC3	DC5	DC12	DC13	DC14
Mat. contacts AgNi, contact 16A	250V / 6A	250V / 6A	250V / 6A	24V / 16A	24V / 6A	24V / 4A	24V / 16A	24V / 2A	24V / 2A

HRH-1

Function:	3
Supply terminals:	A1 - A2
Voltage range:	AC 110 V, AC 230 V or AC/DC 24 V galvanically separated (AC 50 - 60 Hz)
Power input:	max. 4.5 VA
Supply voltage tolerance:	-15 %; +10 %

Measuring circuit

Hysteresis (input - opening):	in an adjustable range 5 kΩ - 100 kΩ
Voltage on electrode:	max. AC 5 V
Current in probes:	AC < 1 mA
Time reaction:	max. 400 ms
Max. cable capacity:	4 nF
Time delay tD:	adjustable, 0.5 - 10 sec
Time delay tH:	adjustable, 0.5 - 10 sec

Accuracy

Setting accuracy (mech.):	± 5 %
---------------------------	-------

Output

Number of contacts:	2x changeover / SPDT (AgNi / Silver Alloy)
Current rating:	16 A / AC1
Breaking capacity:	4000 VA / AC1, 384 W / DC
Inrush current:	30 A / < 3 s
Switching voltage:	250 V AC1 / 24 V DC
Mechanical life:	3x10 <sup>7</sup>
Electrical life (AC1):	0.7x10 <sup>5</sup>

Other information

Operating temperature:	-20 °C to 55 °C (-4 °F to 131 °F)
Storage temperature:	-30 °C to 70 °C (-22 °F to 158 °F)
Electrical strength:	4 kV (supply - output)
Operating position:	any
Mounting:	DIN rail EN 60715
Protection degree:	IP40 from front panel / IP20 terminals
Overvoltage category:	III.
Pollution degree:	2
Max. cable size (mm <sup>2</sup> ):	solid wire max. 1x 2.5, max. 2x 1.5 / with sleeve max. 1x 1.5 (AWG 12)
Dimensions:	90 x 52 x 65 mm (3.5" x 2" x 2.6")
Weight:	9 oz (256 g) (110V, 230 V); 5.6 oz (158 g) (24 V)
Standards:	EN 60255-6, EN 61010-1

Two separate level switches

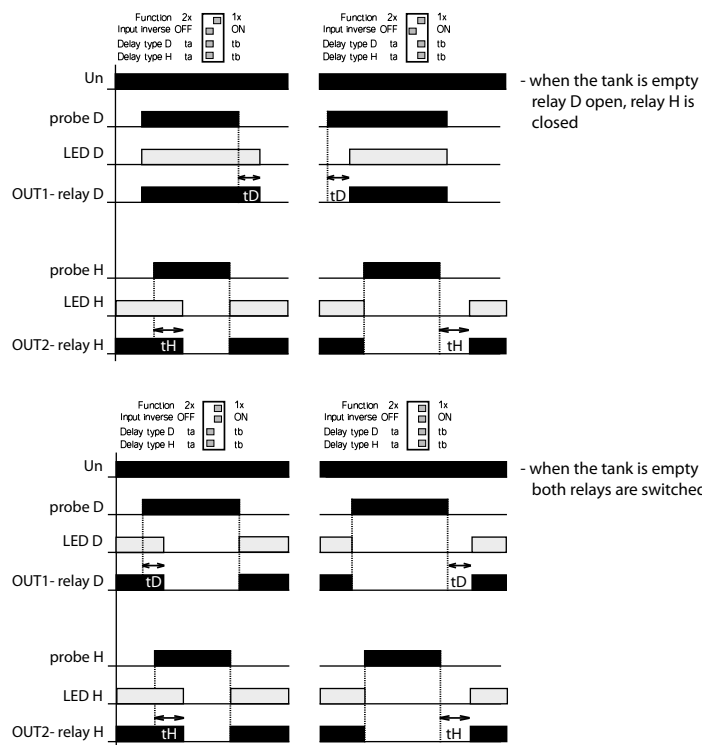

Two probes in single tank

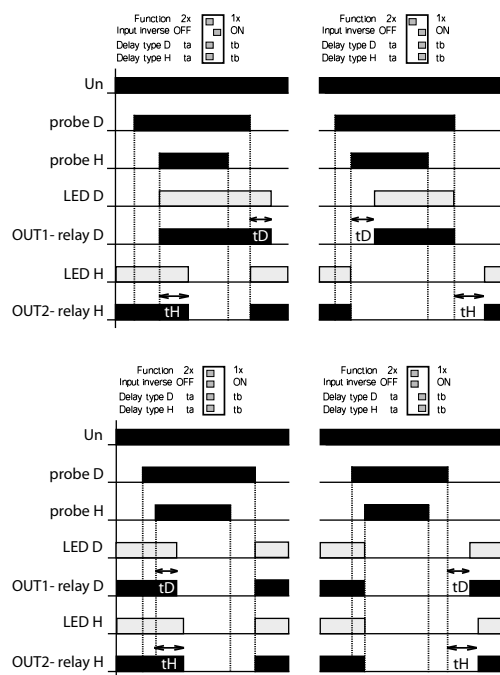

The relay, which is used to control the level liquids conductive (water, chemical solutions, food, etc.).

In this principle, it goes on about the measurement of liquids by measuring probes. As the measuring used signal is 5 V AC / 500 Hz. Using an AC signal prevents the the increasing oxidation of probes and unwanted polarization and electrolysis liquid. During depending on the DIP settings configurations, switches can control two independent levels or use a combined function for one level (see diagram of functions).

The relay is equipped with regulation of the sensitivity to to liquid resistance. It's also possible to eliminate some of the unwanted switching in the sensitivity settings according to specific conditions (for example, pollution probe sediments, humidity, etc.). It's also possible for each probe to set the delay in the range of 0.5 - 10 s, and using the DIP switch type delay (when you turn the relay on and off, depending on application).

For controlling two independent tanks

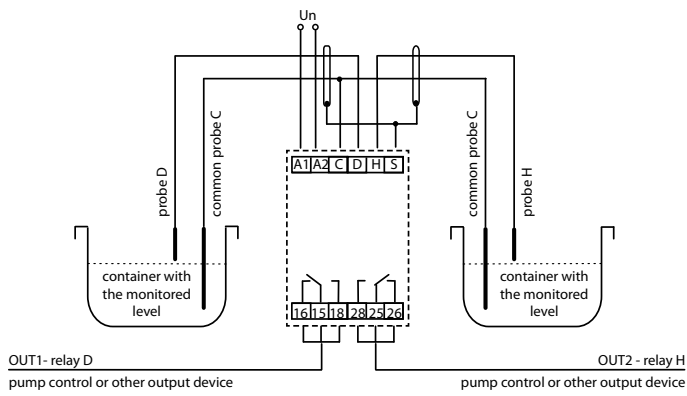

For controlling the level combination of upper and bottom probe

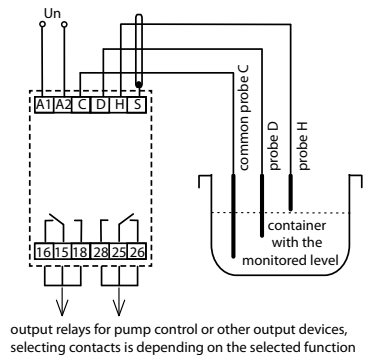

Note:

As a common probe, it could be used with an advantage such as metal pipes, tanks, etc. Due to the isolation of probes from a supply voltage, and the measured voltage which is up to 5 V, it is possible to connect probes using standard communication cables.

There can be any measuring probe (any conductive contact, it is recommended to use brass or stainless steel).

The probe wire does not need to be shielded, but it is recommended. When using a shielded wire, the shielding is connected to terminal S.

- Manufacturer's recommended probes:
  - SHR-1-N - stainless steel sensor
  - SHR-1-M - brass sensor
  - SHR-2 - stainless steel mounted in PVC cover
  - SHR-3 - stainless probe intended to be used in harsh industrial environments
  - FP-1 - flood probe
- Factory recommended conductor (certified to be used in drinking water):
  - Three-wire cable D03VV-F 3x0.75/3.2
  - Cable D05V-K 0.75/3.2

Warning

The device is constructed to be connected into 1-phase main and must be installed in accordance with regulations and norms applicable in a particular country. Installation, connection and setting can be done only by a person with an adequate electro-technical qualification which has read and understood this instruction manual and product elements in the supply main. Too ensure correct function of these protection elements it is necessary to front-end other protective elements of higher degree (A,B,C) and screening of disturbances of switched devices (contactors, motors, inductive load etc.) as it is stated in a standard. Before you start with installation, make sure that the device is not energized and that the main switch is OFF. Do not install the device to the sources of excessive electromagnetic disturbances. By correct installation, ensure good air circulation so the maximal allowed operational temperature is not exceeded in case of permanent operation and higher ambient temperature. While installing the device use screwdriver width approx. 2 mm. Keep in mind that this device is fully electronic while installing. Correct function of the device is also depended on transportation, storing and handling. In case you notice any signs of damage, deformation, malfunction or missing piece, do not install this device and claim it at the seller. After operational life treat the product as electronic waste.